



中国认可
国际互认
检测
TESTING
CNAS L2291



Access to the World

TEST REPORT

Product Name : All-in-one solar charge inverter

Model Number : See page 6 section 2.1

Prepared for : SRNE Solar Co.,Ltd
Address : 4-5F,Building13A,Taihua Wutong Industrial Park ,Gushu
Development Zone ,Hangcheng Street,Baoan, Shenzhen,
China PR

Prepared by : EMTEK (SHENZHEN) CO., LTD.
Address : Building 69, Majialong Industry Zone, Nanshan District,
Shenzhen, Guangdong, China

Tel: (0755) 26954280
Fax: (0755) 26954282

Report Number : ENS2205190008E00101R
Date(s) of Tests : May 23, 2022 to June 14, 2022
Date of issue : June 14, 2022



TABLE OF CONTENT

Test Report Description	Page
1. SUMMARY OF TEST RESULTS.....	5
2. GENERAL INFORMATION	6
2.1. Description of Device (EUT)	6
2.2. Independent Operation Modes	6
2.3. Test Manner	7
2.4. Description of Test Facility	7
2.5. Test Software	7
2.6. Description of Support Device	8
2.7. Measurement Uncertainty.....	8
3. MEASURING DEVICE AND TEST EQUIPMENT.....	9
3.1. For Conducted Emission Measurement	9
3.2. For Radiated Emission Measurement	9
4. POWER LINE CONDUCTED EMISSION MEASUREMENT	10
4.1. Block Diagram of Test Setup	10
4.2. Limits.....	10
4.3. Test Procedure.....	10
4.4. Measuring Results	11
5. RADIATED EMISSION MEASUREMENT(UP TO 1GHz).....	14
5.1. Block Diagram of Test Setup	14
5.2. Radiated Limit.....	14
5.3. Test Procedure.....	14
5.4. Measuring Results	15
6. PHOTOGRAPHS.....	20
6.1. Photos of Conducted Emission Measurement	20
6.2. Photos of Radiation Emission Measurement	21
APPENDIX A: Label Requirements (1 Page)	
APPENDIX B: Warning Statement (1 Page)	
APPENDIX C: Photos of EUT (3 Pages)	

TEST REPORT DESCRIPTION

Applicant : SRNE Solar Co.,Ltd
Manufacturer : SRNE SOLAR CO.,LTD Dongguan Branch
Trade Mark : SRNE
EUT : All-in-one solar charge inverter
Model No. : See page 6 section 2.1
Power Supply : AC Input: AC 90~140V, 50/60Hz
PV Input: DC 120~450V, 5500W
Battery Input: DC 40~60V
AC Output: AC 120V±5%, 5500W
PV Output: 5000W, 80A

Measurement Procedure Used:

FCC CFR Title 47, Part 15, Subpart B
ANSI C63.4-2014

The device described above is tested by EMTEK (SHENZHEN) CO., LTD. to determine the maximum emission levels emanating from the device and the severe levels of the device can endure and its performance criterion. The measurement results are contained in this test report and EMTEK (SHENZHEN) CO., LTD. is assumed full of responsibility for the accuracy and completeness of these measurements. Also, this report shows that the EUT (Equipment Under Test) is technically compliant with the FCC requirements.

This report applies to above tested sample only and shall not be reproduced in part without written approval of EMTEK (SHENZHEN) CO., LTD.

Date of Test : May 23, 2022 to June 14, 2022

Prepared by : Kangtao Zhang
Kangtao Zhang/Editor

Reviewer : Jessie Hu
Jessie Hu/Supervisor

Approved & Authorized Signer : Lisa Wang
Lisa Wang/Manager

Modified Information

Version	Report No.	Revision Data	Summary
Ver.1.0	ENS2205190008E00101R	/	Original Version



1. SUMMARY OF TEST RESULTS

EMISSION		
Description of Test Item	Standard & Limits	Results
Conducted Emission at Mains Terminals	FCC CFR Title 47, Part 15, Subpart B, Class B ANSI C63.4-2014	Pass
Radiated Emission	FCC CFR Title 47, Part 15, Subpart B, Class B ANSI C63.4-2014	Pass



2. GENERAL INFORMATION

2.1. Description of Device (EUT)

EUT	: All-in-one solar charge inverter
Model Number	: HF2415U60-H, HF2420S40-H, HF2420S60-H, HF2420S80-H, HF2420U60-H, HF2430S40-H, HF2430S60-H, HF2430S80-H, HF2430U60-H, HF4825U60-145, HF4825U60-H, HF4825U80-145, HF4825U80-H, HF4830S100-H, HF4830S60-145, HF4830S60-H, HF4830S80-145, HF4830S80-H, HF4830U60-145, HF4830U60-H, HF4830U80-145, HF4830U80-H, HF4835U60-H, HF4835U80-145, HF4835U80-H, HF4840S100-H, HF4840S60-145, HF4840S60-H, HF4840S80-145, HF4840S80-H, HF4850S100-H, HF4850S80-145, HF4850S80-H, HF4850U80-H, HFP4835U80-145, HFP4835U80-H, HFP4850S80-145, HFP4850S80-H, HFP4850U80-H, MF4830S60-H, MF4835U60-H, MF4850S80-H, MF4850U80-H, HF4856S80-H, HF4856U80-H, HFP4856S80-H, HFP4856U80-H, RIV4835CSH1S, RIV4835PCS-1SS, RIV4850PCS-1SS, HF2436S80-H, HF2436U80-H (Note: These models are identical in circuitry and electrical, mechanical, and physical structure; The only differences are trade name, model number, rated voltage and power. The purpose of the transaction. We prepare the test for HF4850U80-H.)
Applicant	: SRNE Solar Co.,Ltd
Address	: 4-5F,Building13A,Taihua Wutong Industrial Park ,Gushu Development Zone ,Hangcheng Street,Baoan, Shenzhen, China PR
Manufacturer	: SRNE SOLAR CO.,LTD Dongguan Branch
Address	: Room 301, Building 5th, Fuxing Rd No.36, Chang'an Town, Dongguan City, Guangdong Province, China PR
Factory	: SRNE SOLAR CO.,LTD Dongguan Branch
Address	: Room 301, Building 5th, Fuxing Rd No.36, Chang'an Town, Dongguan City, Guangdong Province, China PR
Date of Received	: May 23, 2022
Date of Test	: May 23, 2022 to June 14, 2022

2.2. Independent Operation Modes

- A. On
1. AC Charging mode
 2. PV Charging
 3. Discharging

2.3. Test Manner

Test Items	Test Voltage	Operation Modes	Worst case
Conducted Emission	AC120V/60Hz, DC 48V(Bat), DC450V(PV)	Mode A	Mode A.1
Radiated emissions (Up to 1 GHz)	AC120V/60Hz, DC 48V(Bat), DC450V(PV)	Mode A	Mode A.1

2.4. Description of Test Facility

Site Description

EMC Lab.

: **Accredited by CNAS**

The Certificate Registration Number is L2291.

The Laboratory has been assessed and proved to be in compliance with CNAS-CL01 (identical to ISO/IEC 17025:2017)

Accredited by FCC

Designation Number: CN1204

Test Firm Registration Number: 882943

Accredited by A2LA

The Certificate Number is 4321.01.

Accredited by Industry Canada

The Conformity Assessment Body Identifier is CN0008

Name of Firm : EMTEK (SHENZHEN) CO., LTD.

Site Location : Building 69, Majialong Industry Zone, Nanshan District, Shenzhen, Guangdong, China

2.5. Test Software

Item

Software

Conducted Emission

: EMTEK(Ver.CON-03A1)-Shenzhen

Radiated Emission : EMTEK(Ver.RA-03A1)-Shenzhen

2.6. Description of Support Device

N/A

2.7. Measurement Uncertainty

Test Item	Uncertainty
Conducted Emission Uncertainty	: 3.16dB (9k~150kHz Conduction 2#) 2.90dB (150k~30MHz Conduction 2#)
Radiated Emission Uncertainty (3m 3# Chamber)	: 4.40dB (30M~1GHz Polarize: H) 5.04dB (30M~1GHz Polarize: V)
Uncertainty for test site temperature and humidity	: 0.6°C 4%



3. MEASURING DEVICE AND TEST EQUIPMENT

3.1. For Conducted Emission Measurement

Used	Equipment	Manufacturer	Model No.	Serial No.	Last Cal.	Cal. Interval
<input checked="" type="checkbox"/>	EMI Test Receiver	Rohde & Schwarz	ESCI	101045	May 14, 2022	1 Year
<input checked="" type="checkbox"/>	PULSE LIMITER	Rohde & Schwarz	ESH3-Z2	100107	May 14, 2022	1 Year
<input checked="" type="checkbox"/>	AMN	Schwarzbeck	NNLK 8129	8129203	May 15, 2022	1 Year

3.2. For Radiated Emission Measurement

Used	Equipment	Manufacturer	Model No.	Serial No.	Last Cal.	Cal. Interval
<input checked="" type="checkbox"/>	EMI Test Receiver	Rohde & Schwarz	ESU 26	100154	May 14, 2022	1 Year
<input checked="" type="checkbox"/>	Pre-Amplifier	Lunar EM	LNA30M3G-25	J10100000070	May 14, 2022	1 Year
<input checked="" type="checkbox"/>	Bilog Antenna	Schwarzbeck	VULB9163	659	Aug. 22, 2021	2 Year

4. POWER LINE CONDUCTED EMISSION MEASUREMENT

4.1. Block Diagram of Test Setup

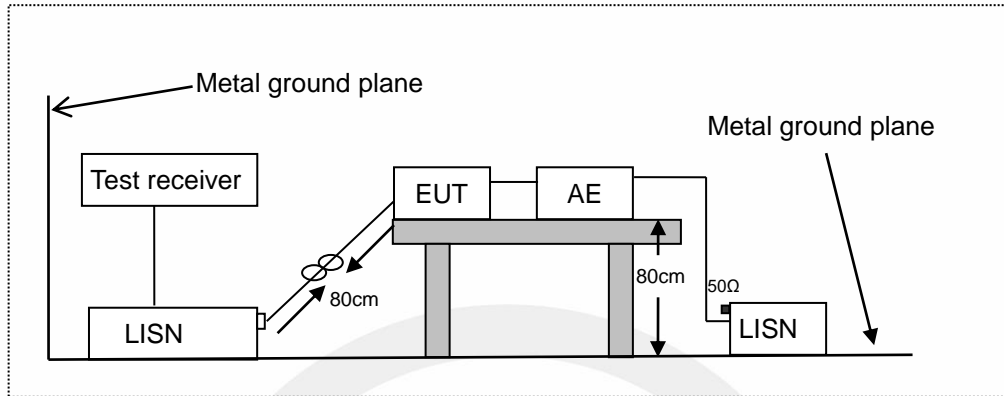

LISN: Line Impedance Stabilization Network
 AE: Associated equipment
 EUT: Equipment under test

4.2. Limits

FCC Part 15, Subpart B, Class B

Frequency (MHz)	Limit (dB μ V)	
	Quasi-peak Level	Average Level
0.15 ~ 0.50	66.0 ~ 56.0 *	56.0 ~ 46.0 *
0.50 ~ 5.00	56.0	46.0
5.00 ~ 30.00	60.0	50.0

NOTE1-The lower limit shall apply at the transition frequencies.
 NOTE2-The limit decreases linearly with the logarithm of the frequency in the range 0.15MHz to 0.50MHz.

4.3. Test Procedure

The EUT was placed on a table 0.8 m height from the metal ground plane and 0.4 m from the conducting wall of the shielding room and it was kept at least 0.8 m from any other grounded conducting surface.

All units of equipment forming the system under test (includes the EUT as well as connected peripherals and associated equipment or devices) shall be arranged such that a nominal 0.1 m separation is achieved between the neighboring units.

Connect EUT to the power mains through a artificial mains network (AMN). Where the mains cable supplied by the manufacturer is longer than 1 m, the excess should be folded at the centre into a bundle no longer than 0.4 m, so that its length is shortened to 1 m.

All the support units are connecting to the other LISN.

The LISN provides 50 ohm coupling impedance for the measuring instrument.

Both sides of AC line were checked for maximum conducted interference.

The frequency range from 150 kHz to 30 MHz was sweep.

Set the test-receiver system to quasi peak detect function and average detect function, and to measure the conducted emissions values.

Test results were obtained from the following equation:

Emission Level (dB μ V) = LISN Factor (dB) + Cable Loss (dB) + Reading (dB μ V)

Margin (dB) = Emission Level (dB μ V) - Limit (dB μ V)

4.4. Measuring Results

PASS.

All the modes were tested and the data of the worst modes are attached the following pages.

Temperature	:	25.1°C
Humidity	:	45%
Atmospheric Pressure	:	101kpa
Test Engineer	:	HL
Test Date	:	2022-05-27

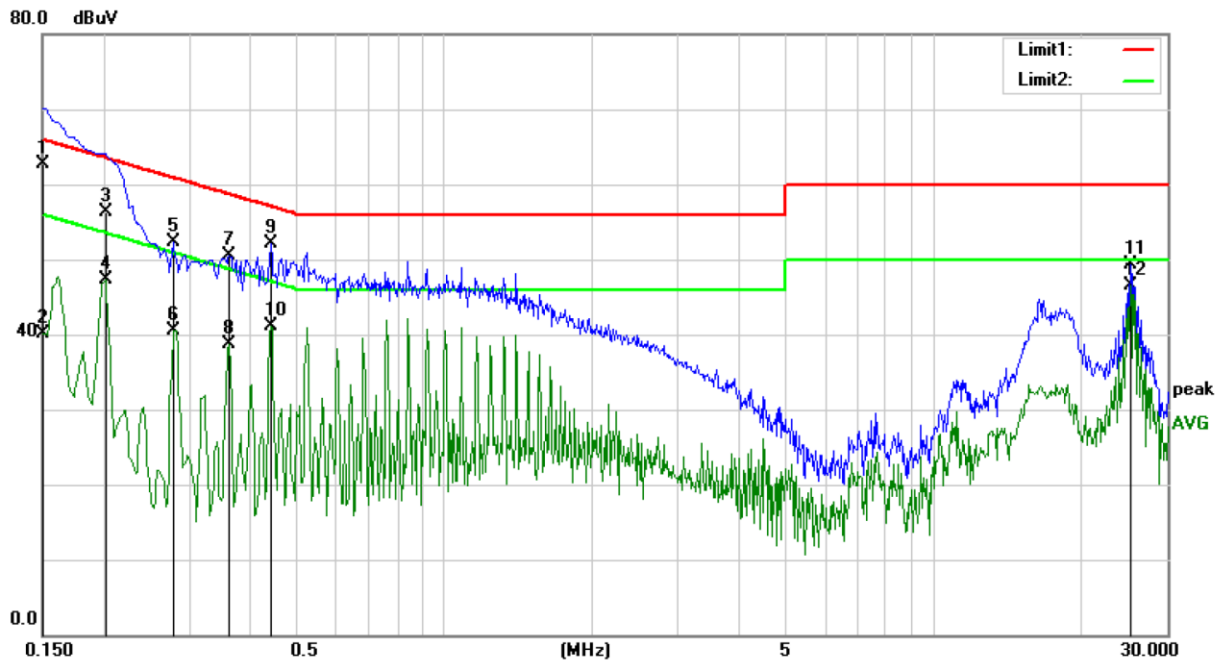

Site Conduction #2

Phase: **L1**

Temperature: 25.1

Limit: (CE)FCC PART 15 class B_QP

Power: PV 360V/22A+AC 120V/60Hz Humidity: 45 %

Mode: AC charging

Note:

No.	Mk.	Freq. MHz	Reading Level dBuV	Correct Factor dB	Measure- ment dBuV	Limit dBuV	Over dB	Detector	Comment
1	*	0.1500	52.71	10.09	62.80	66.00	-3.20	QP	
2		0.1500	30.11	10.09	40.20	56.00	-15.80	AVG	
3		0.2020	46.30	10.10	56.40	63.53	-7.13	QP	
4		0.2020	37.21	10.10	47.31	53.53	-6.22	AVG	
5		0.2780	42.23	10.09	52.32	60.88	-8.56	QP	
6		0.2780	30.50	10.09	40.59	50.88	-10.29	AVG	
7		0.3620	40.36	10.10	50.46	58.68	-8.22	QP	
8		0.3620	28.53	10.10	38.63	48.68	-10.05	AVG	
9		0.4420	42.04	10.10	52.14	57.02	-4.88	QP	
10		0.4420	30.92	10.10	41.02	47.02	-6.00	AVG	
11		25.2860	38.60	10.64	49.24	60.00	-10.76	QP	
12		25.2860	35.86	10.64	46.50	50.00	-3.50	AVG	

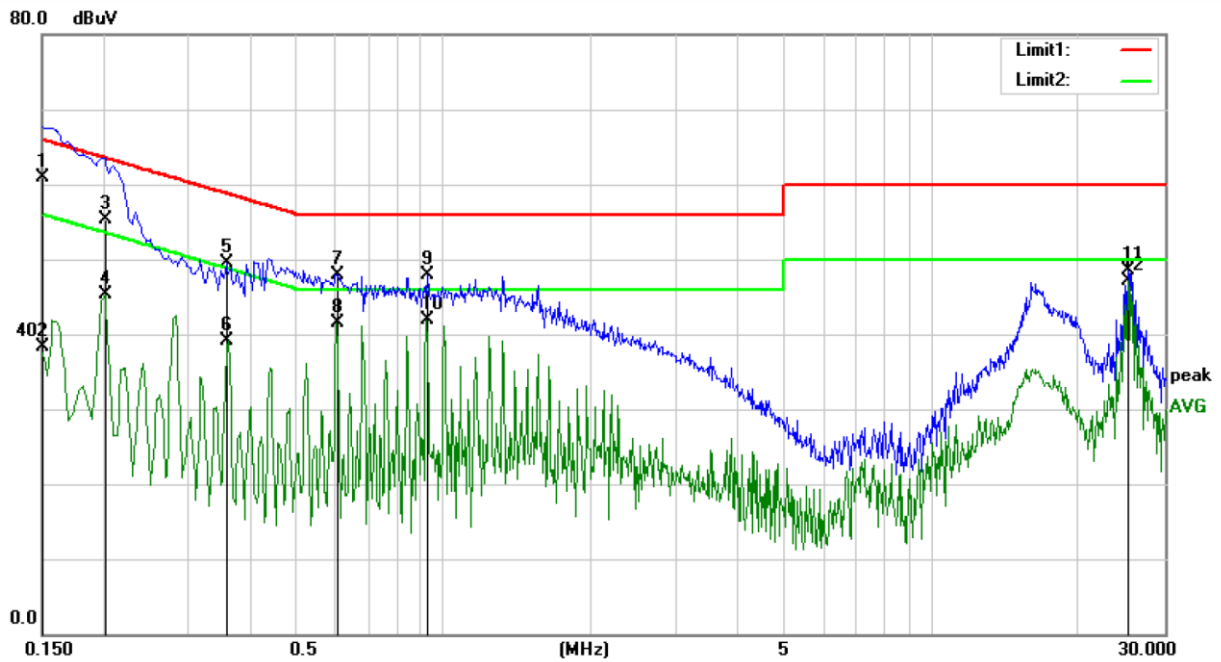

Site Conduction #2

Phase: **N**

Temperature: 25.1

Limit: (CE)FCC PART 15 class B_QP

Power: PV 360V/22A+AC 120V/60Hz

Humidity: 45 %

Mode: AC charging

Note:

No.	Mk.	Freq. MHz	Reading Level dBuV	Correct Factor dB	Measure- ment dBuV	Limit dBuV	Over dB	Detector	Comment
1		0.1500	50.91	10.09	61.00	66.00	-5.00	QP	
2		0.1500	28.16	10.09	38.25	56.00	-17.75	AVG	
3		0.2020	45.30	10.10	55.40	63.53	-8.13	QP	
4		0.2020	35.11	10.10	45.21	53.53	-8.32	AVG	
5		0.3580	39.36	10.10	49.46	58.77	-9.31	QP	
6		0.3580	28.99	10.10	39.09	48.77	-9.68	AVG	
7		0.6060	37.86	10.12	47.98	56.00	-8.02	QP	
8		0.6060	31.40	10.12	41.52	46.00	-4.48	AVG	
9		0.9260	37.78	10.17	47.95	56.00	-8.05	QP	
10		0.9260	31.75	10.17	41.92	46.00	-4.08	AVG	
11		25.2860	37.95	10.64	48.59	60.00	-11.41	QP	
12	*	25.2860	36.43	10.64	47.07	50.00	-2.93	AVG	

5. RADIATED EMISSION MEASUREMENT(UP TO 1GHz)

5.1. Block Diagram of Test Setup

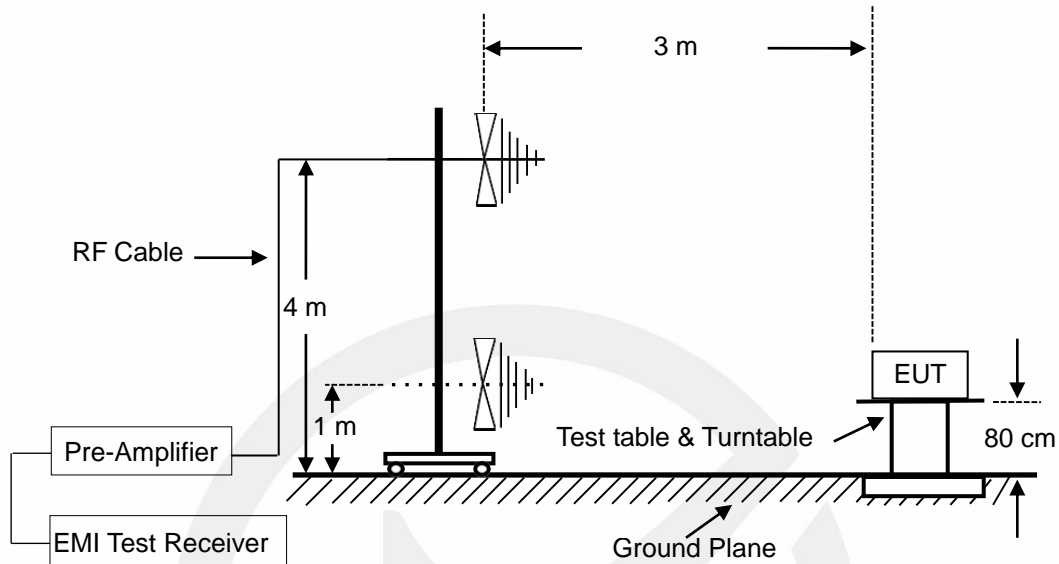

5.2. Radiated Limit

FCC Part 15, Subpart B, Class B

Frequency MHz	Distance Meters	Field Strengths Limit	
		$\mu\text{V}/\text{m}$	$\text{dB}(\mu\text{V})/\text{m}$
30 ~ 88	3	100	40.0
88 ~ 216	3	150	43.5
216 ~ 960	3	200	46.0
960 ~ 1000	3	500	54.0

5.3. Test Procedure

The EUT was placed on a non-conductive table whose total height equaled 80cm. All units of equipment forming the system under test (includes the EUT as well as connected peripherals and associated equipment or devices) shall be arranged such that a nominal 0.1 m separation is achieved between the neighboring units.

The EUT was set 3 meters (or 10 meters) away from the receiving antenna that was mounted on a non-conductive mast. The antenna can move up and down between 1 to 4 meters to find out the maximum emission level.

The turntable can rotate 360 degree to determine the position of the maximum emission level.

The initial testing identified the frequency that has the highest disturbance relative to the limit while operating the EUT in typical modes of operation and cable positions in a test setup representative of typical system configuration.

The identification of the frequency of highest emission with respect to the limit was found by investigating emissions at a number of significant frequencies. The probable frequency of maximum emission had been found and that the associated cable and EUT configuration and mode of operation had been identified.

The bandwidth of the Receiver is set at 120 kHz.

Test results were obtained from the following equation:

Emission level (dB μ V/m) = Antenna Factor - Amp Factor + Cable Loss + Reading

Margin (dB) = Emission Level (dB μ V/m) - Limit (dB μ V/m)

5.4. Measuring Results

PASS.

Please see the attached pages.

Temperature	:	25.7°C
Humidity	:	55%
Atmospheric Pressure	:	101kpa
Test Engineer	:	YXL
Test Date	:	2022-06-13

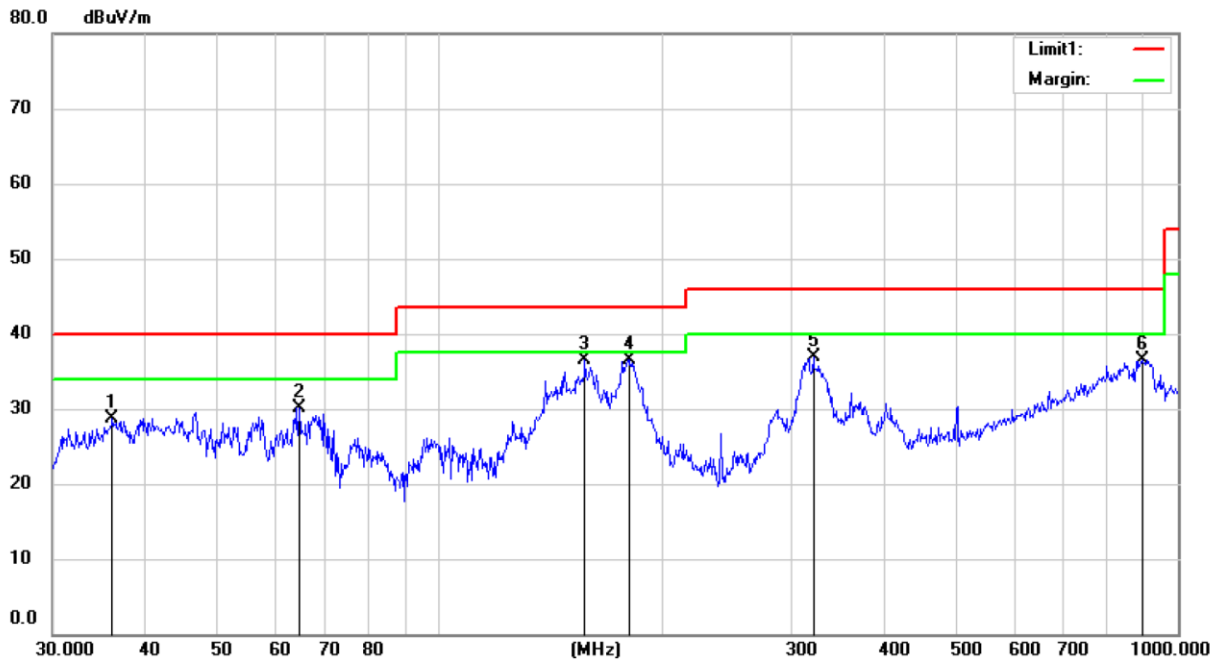

Site 3m Chamber #3 Polarization: **Horizontal** Temperature: 25.7 C
 Limit: (RE)FCC PART 15 CLASS B Power: DC 48V Humidity: 55 %
 Mode: Discharging
 Note:

No.	Mk.	Freq.	Reading Level	Correct Factor	Measurement	Limit	Over	Antenna Height	Table Degree	
		MHz	dBuV	dB	dBuV/m	dBuV/m	dB	cm	degree	Comment
1		36.1272	38.82	-10.11	28.71	40.00	-11.29	QP		
2		64.6594	38.88	-8.75	30.13	40.00	-9.87	QP		
3	*	157.5588	47.89	-11.35	36.54	43.50	-6.96	QP		
4		180.6488	48.06	-11.54	36.52	43.50	-6.98	QP		
5		321.0608	43.49	-6.58	36.91	46.00	-9.09	QP		
6		896.9965	30.43	6.16	36.59	46.00	-9.41	QP		

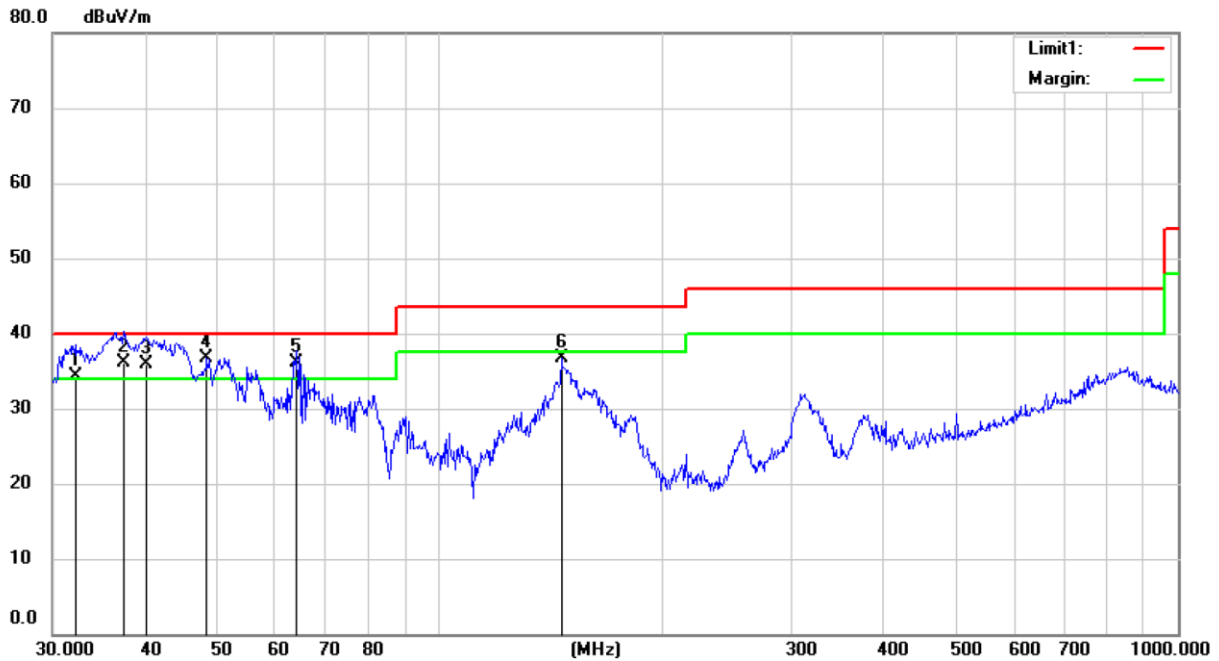

Site 3m Chamber #3 Polarization: **Vertical** Temperature: 25.7 C
 Limit: (RE)FCC PART 15 CLASS B Power: DC 48V Humidity: 55 %
 Mode: Discharging
 Note:

No.	Mk.	Freq.	Reading Level	Correct Factor	Measurement	Limit	Over	Antenna Height	Table Degree	
		MHz	dBuV	dB	dBuV/m	dBuV/m	dB	cm	degree	Comment
1	!	32.1795	45.40	-11.00	34.40	40.00	-5.60			QP
2	!	37.4165	46.18	-9.98	36.20	40.00	-3.80			QP
3	!	40.1347	45.42	-9.52	35.90	40.00	-4.10			QP
4	*	48.5016	45.85	-9.08	36.77	40.00	-3.23			QP
5	!	64.2074	44.93	-8.73	36.20	40.00	-3.80			QP
6		146.3735	48.17	-11.44	36.73	43.50	-6.77			QP

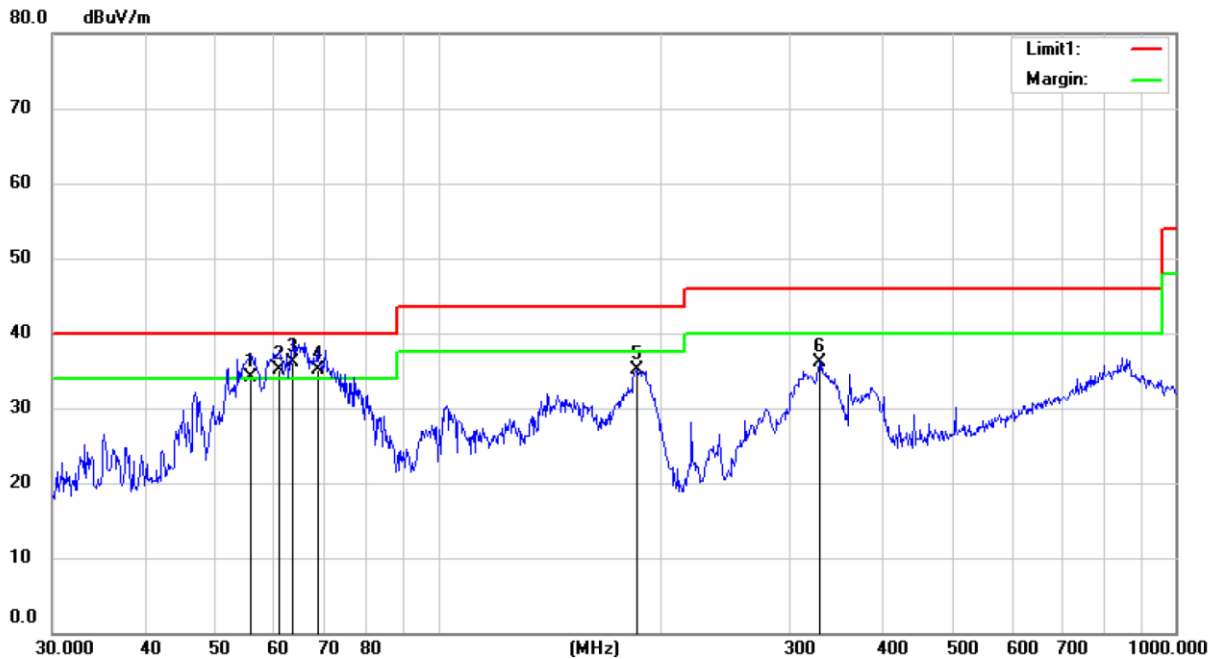

Site 3m Chamber #3

Polarization: **Horizontal**

Temperature: 25.7 C

Limit: (RE)FCC PART 15 CLASS B

Power: PV 360V/22A+AC 120V/60Hz

Humidity: 55 %

Mode: AC charging mode

Note:

No.	Mk.	Freq.	Reading Level	Correct Factor	Measurement	Limit	Over	Antenna Height	Table Degree	
		MHz	dBuV	dB	dBuV/m	dBuV/m	dB	cm	degree	Comment
1	!	55.6094	42.82	-8.62	34.20	40.00	-5.80			QP
2	!	60.9176	43.72	-8.62	35.10	40.00	-4.90			QP
3	*	63.5356	44.91	-8.71	36.20	40.00	-3.80			QP
4	!	68.6310	44.65	-9.55	35.10	40.00	-4.90			QP
5		185.7882	46.31	-11.20	35.11	43.50	-8.39			QP
6		329.0390	42.30	-6.13	36.17	46.00	-9.83			QP

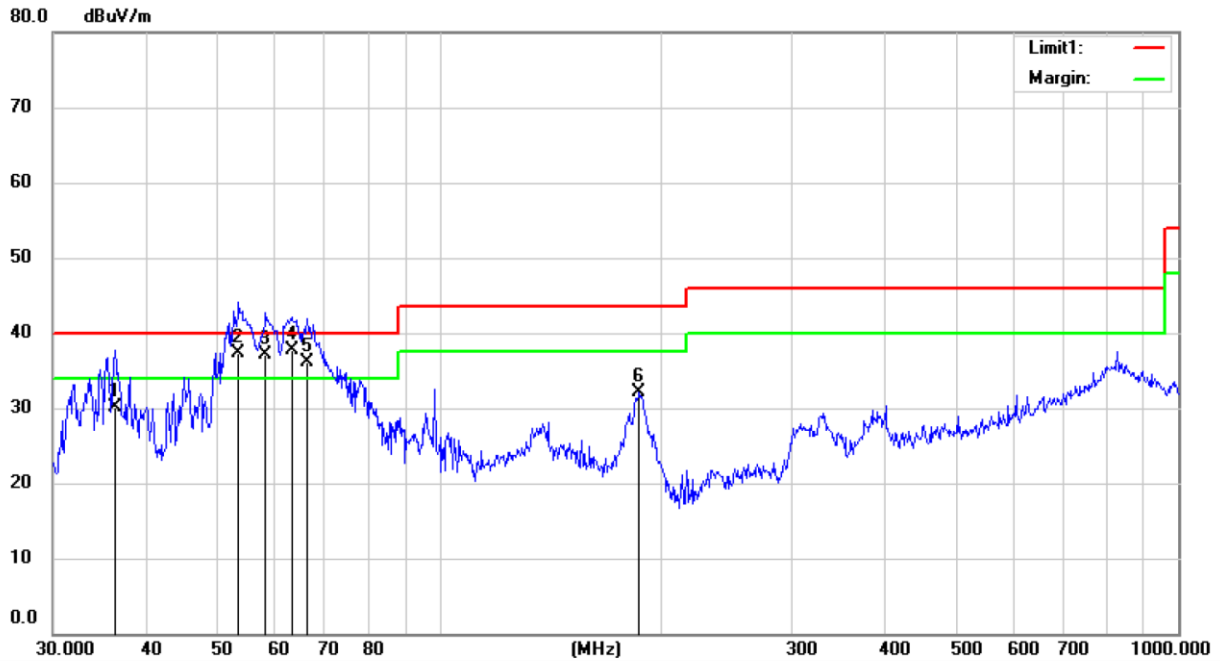

Site 3m Chamber #3 Polarization: **Vertical** Temperature: 25.7 C
 Limit: (RE)FCC PART 15 CLASS B Power: PV 360V/22A+AC 120V/60Hz Humidity: 55 %
 Mode: AC charging mode
 Note:

No.	Mk.	Freq. MHz	Reading Level dBuV	Correct Factor dB	Measure- ment dBuV/m	Limit dBuV/m	Over dB	Detector	Antenna Height cm	Table Degree	Comment
1		36.3814	40.18	-10.08	30.10	40.00	-9.90	QP			
2	!	53.5052	46.06	-8.66	37.40	40.00	-2.60	QP			
3	!	58.2030	45.88	-8.68	37.20	40.00	-2.80	QP			
4	*	63.0916	46.48	-8.68	37.80	40.00	-2.20	QP			
5	!	66.2662	45.13	-9.03	36.10	40.00	-3.90	QP			
6		186.4410	43.35	-11.24	32.11	43.50	-11.39	QP			

6. PHOTOGRAPHS

6.1. Photos of Conducted Emission Measurement



6.2. Photos of Radiation Emission Measurement

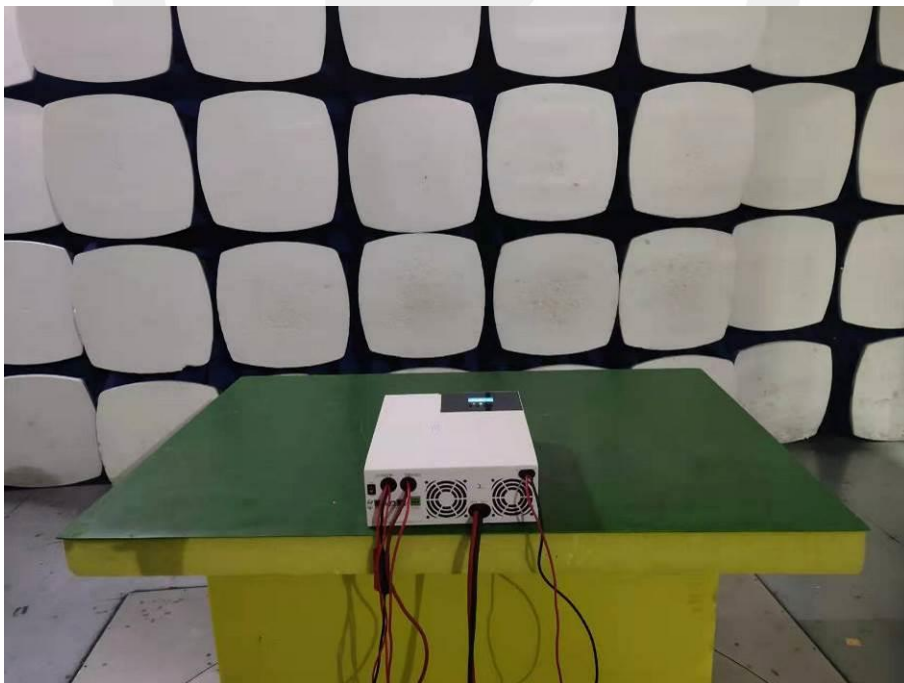

APPENDIX A: Label Requirements

(1) Receivers associated with the operation of a licensed radio service, e.g., FM broadcast under part 73 of this chapter, land mobile operation under part 90 of this chapter, etc., shall bear the following statement in a conspicuous location on the device:

This device complies with part 15 of the FCC Rules. Operation is subject to the condition that this device does not cause harmful interference.

(2) A stand-alone cable input selector switch, shall bear the following statement in a conspicuous location on the device:

This device complies with part 15 of the FCC Rules for use with cable television service.

(3) All other devices shall bear the following statement in a conspicuous location on the device:

This device complies with part 15 of the FCC Rules. Operation is subject to the following two conditions: (1) This device may not cause harmful interference, and (2) this device must accept any interference received, including interference that may cause undesired operation.

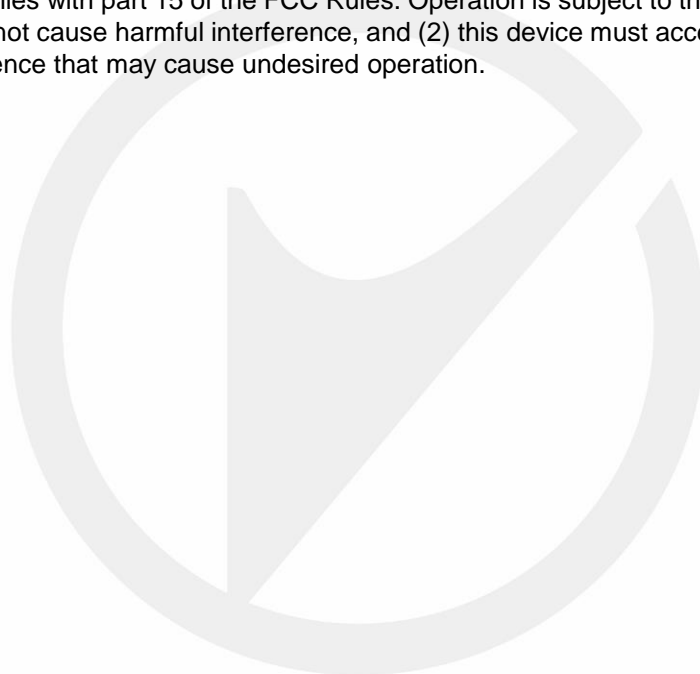

APPENDIX B: Warning Statement

(a) For a Class A digital device or peripheral, the instructions furnished the user shall include the following or similar statement, placed in a prominent location in the text of the manual:

NOTE: This equipment has been tested and found to comply with the limits for a Class A digital device, pursuant to part 15 of the FCC Rules. These limits are designed to provide reasonable protection against harmful interference when the equipment is operated in a commercial environment. This equipment generates, uses, and can radiate radio frequency energy and, if not installed and used in accordance with the instruction manual, may cause harmful interference to radio communications. Operation of this equipment in a residential area is likely to cause harmful interference in which case the user will be required to correct the interference at his own expense.

(b) For a Class B digital device or peripheral, the instructions furnished the user shall include the following or similar statement, placed in a prominent location in the text of the manual:

NOTE: This equipment has been tested and found to comply with the limits for a Class B digital device, pursuant to part 15 of the FCC Rules. These limits are designed to provide reasonable protection against harmful interference in a residential installation. This equipment generates, uses and can radiate radio frequency energy and, if not installed and used in accordance with the instructions, may cause harmful interference to radio communications. However, there is no guarantee that interference will not occur in a particular installation. If this equipment does cause harmful interference to radio or television reception, which can be determined by turning the equipment off and on, the user is encouraged to try to correct the interference by one or more of the following measures:

- Reorient or relocate the receiving antenna.
- Increase the separation between the equipment and receiver.
- Connect the equipment into an outlet on a circuit different from that to which the receiver is connected.
- Consult the dealer or an experienced radio/TV technician for help.

Warning: Changes or modifications to this unit not expressly approved by the party responsible for compliance could void the user's authority to operate the equipment.

APPENDIX C: Photos of EUT

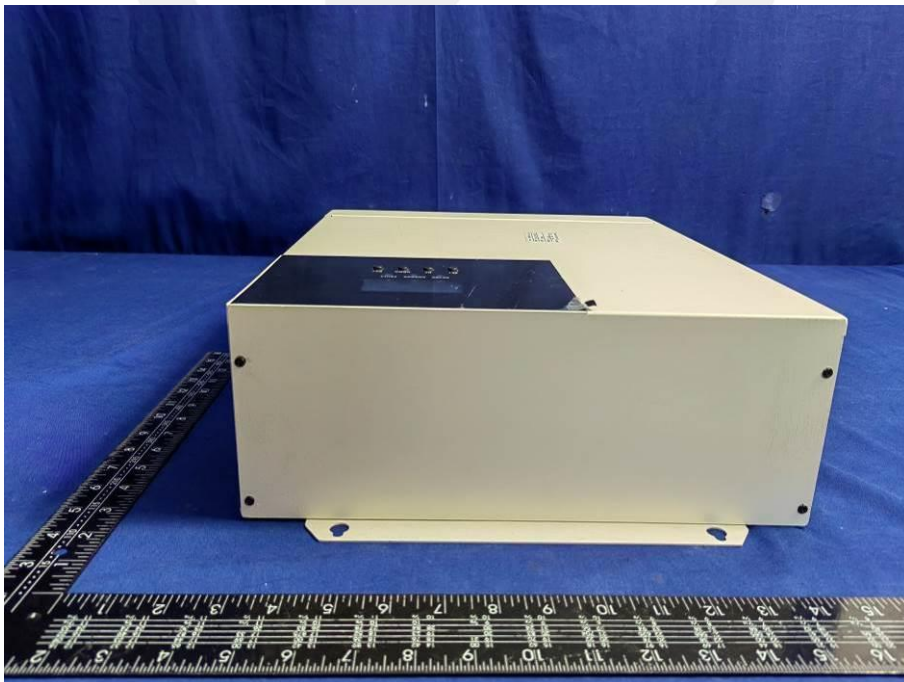
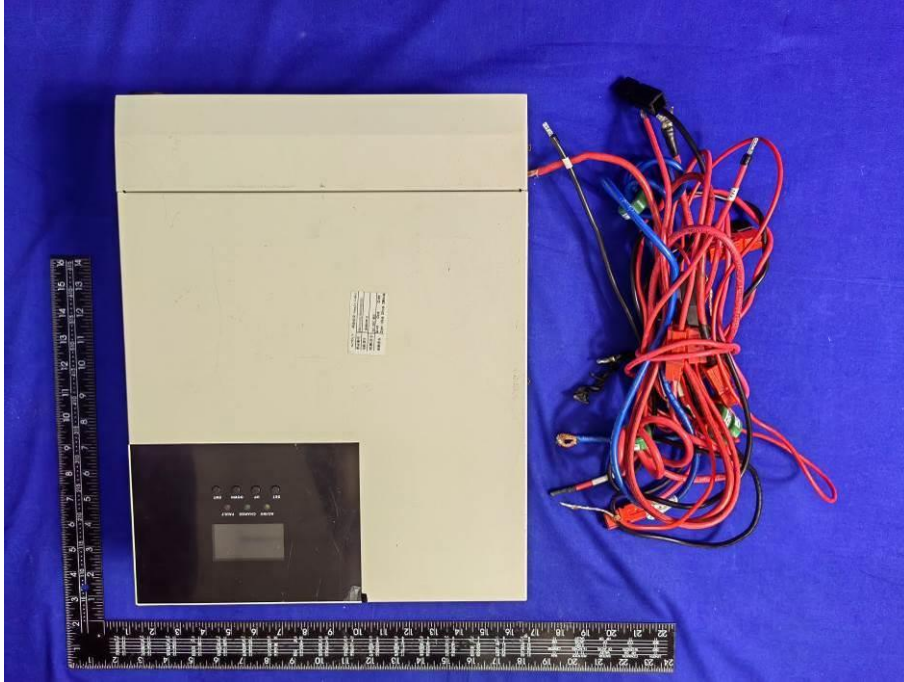



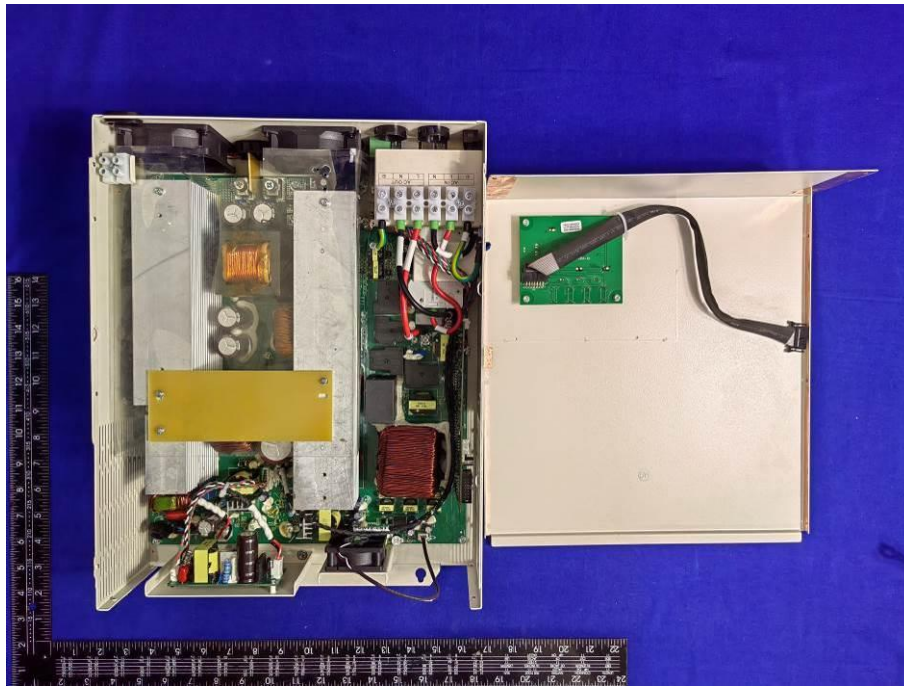

*** End of Report ***

Statement

- 1 . This report is invalid without the signature of the authorized approver and "special seal for testing".
- 2 . This report shall not be copied partly without authorization.
- 3 . The test results or observations are applicable only to tested sample. Client shall be responsible for representativeness of the sample and authenticity of the material.
- 4 . The observations or tests with special mark fall outside the scope of accreditation, and are only used for purpose of commission, research, training, internal quality control etc.
- 5 . The test results or observations are provided in accordance with measured value, without taking risks caused by uncertainty into account. Without explicit stipulation in special agreements, standards or regulations, EMTEK shall not assume any responsibility.
- 6 . Objections shall be raised within 20 days from the date receiving the report.